

Plasterboard & Cornice

installation
manual

Plasterboard
& Cornice



Build it better with **BGC**

BGC

Plasterboard

Australian Owned & Manufactured www.bgc.com.au/plasterboard

History & Mission



BGC Fibre Cement and Plasterboard is a proud Australian owned manufacturer of fibre cement and plasterboard products.

BGC has state-of-the-art manufacturing facilities in Perth and distribution centres in all states of Australia and in New Zealand.

Our distribution network ensures that our entire product range is readily available in all states of Australia.

BGC has a team of technical specialists that can assist with all specification and design information to help ensure that you always **'build it better with BGC'**.

BGC has interests in:

- residential and commercial building
- building and construction products
- contract mining
- civil engineering construction and maintenance
- quarrying
- road transport
- property ownership and management
- insurance

Our mission at BGC is simple – we want to ensure that people can always **'build it better with BGC'**.

In keeping with our mission, we are constantly assessing and improving our products to ensure that we always provide cost effective, high quality and easy-to-use products to the market.



BGC Plasterboard is an interior lining material which provides a blemish free, monolithic surface ready for decorative paint and thin cover finishes for both commercial and residential applications.

BGC Plasterboard is manufactured using a gypsum core covered with a linerboard which is wrapped around the gypsum to protect the core.

Complementing its plasterboard sheet range, BGC Plasterboard manufactures a range of cove and decorative cornices which provide a solution for the finishing of joints between walls and ceilings.

BGC Plasterboard:

- Interior wall lining system
- Suitable for residential & commercial applications
- Cost effective
- Ready for decoration
- Quick and simple to install
- Excellent acoustic performance

Contents

Product Information	4
Benefits	4
Plasterboard Finish Selection	4
Early Fire Indices	4
Sheet Sizes	5
Installation	5
Control Joints	6
Framing	6
Spacing of Frame Members	7
Adhesives, Nails Screws	7
Minimum Nail Fastener Length	7
Minimum Screw Fastener Length	8
Fixing to Framing – Walls	8
Fixing to Framing – Ceilings	9
Exterior Ceilings	10
Installation	10
Garage Areas	11
Considerations	11
Back Blocking	12
Jointing Application	13
Sanding and Finishing	14
Decoration	14
Cove Cornice	15
Decorative Cornice	15

Product Information

BGC Plasterboard is purpose designed as a complete plasterboard wall and lining system, which complies with the requirements of the Building Code of Australia (BCA).

BGC Plasterboard has been tested by the CSIRO (Manufacturing & Infrastructure Technology) in accordance with AS 2588 - 1998: Gypsum Plasterboard; see report DTS698, April 2003.

BGC Plasterboard interior lining provides a blemish free, monolithic, smooth surface ready for decorative paint and thin cover finishes for homes, offices and institutional buildings.

BGC Plasterboard is to be installed as detailed in AS 2589:2007 'Gypsum Linings – Application and Finishes'.

Support framing must conform to the BCA and Australian Standards, be plumb, true and level, prior to the application of the plasterboard, see table 2 page 7. Refer to section 4.2.2 AS2589:2007

BGC Plasterboard may be fixed to timber or CFS (Cold-Formed Steel) light-steel framing or masonry, using plasterboard screws, nails and or adhesive.

Only screws or nails must be used for tiled areas and over existing lining or vapour barriers.

Jointing is effected with Plaster Cement Jointing Compounds and paper tape, to give reinforced crack resistant and seamless surfaces.

Key Benefits

- Cost effective, easy to install drywall system.
- Seamless, smooth monolithic appearance.
- Excellent fire resistance and acoustic performance.
- High serviceability performance.

Plasterboard Finish Selection

Selecting the level of finish of the interior lining depends on the function of the space, lighting and the desired decorative surfaces required.

For most applications, Finish Levels 4 or 5 are used, as detailed in AS 2589:2007.

Level 3 is used, where heavy to medium texture finishes are applied and the lighting is non-critical.

Level 4 is most commonly used in commercial and residential work, where the finishes are satin, flat or low sheen paint systems and the lighting is non-critical.

For large area walls and ceilings, where critical and severe glancing lighting have an effect, a Level 5 finish must be used to minimize any adverse effects of harsh lighting.

Early Fire Hazard Indices

BGC Plasterboard has been tested by the NATA accredited AWTA for fire resistance in accordance with AS 1530.3; see Report Test Number: 7-518246-CN, April 2003.

Ignitability Index	- 13
Spread of Flame Index	- 0
Heat Evolved Index	- 1
Smoke Developed Index	- 3

Sheet Sizes

THICKNESS (mm) & PRODUCT	WIDTH (mm)	SHEET WIDTH (mm)							
		2400	2700	3000	3600	4200	4800	5400	6000
10 Plasterboard	1200	x	x	x	x	x	x	x	x
	1350			x	x	x	x		x
13 Plasterboard	1200	x	x	x	x	x	x	x	x
	1350			x	x	x	x		
10 Ceilingboard	1200	x	x	x	x	x	x	x	x
	1350	x		x	x	x	x		x
10 Water Resistant Plasterboard	1200	x	x	x	x	x	x		x
	1350	x		x	x	x	x		
13 Water Resistant Plasterboard	1200	x	x	x	x	x			
	1350			x	x	x			
13 Fireboard	1200	x	x	x	x				
16 Fireboard	1200	x	x	x	x				
10 Moisture Resistant Flameboard	1200				x		x		
	1350						x		
13 Wet Area Fireboard	1200				x				
16 Wet Area Fireboard	1200		x	x	x				
10 Soundboard	1200				x		x		
	1350						x		
13 Soundboard	1200			x	x				
6.5 Curveboard	1200				x				
13 Impactboard	1200			x	x				

Some sizes may not be available in all states, please check with your local BGC Plasterboard office for availability.

Installation

BGC Plasterboard recommends that this section should be read in conjunction with the architects' specifications to determine the Level of Finishes.

BGC Plasterboard should be installed after all preceding trades have been completed.

Ceilings should be installed first. BGC Ceilingboard should preferably be fixed with their long edges perpendicular to the windows or light sources, to obviate unwanted light reflections across the joints.

For the walls, BGC Plasterboard sheets should be laid with their long edges horizontal, to minimise the number of joints as well as light reflections across the joints. This is most important when Finish Levels 4 or 5 are specified, as indicated in Table 2 page 7.

BGC Plasterboard may be cut by scoring the face side and snapping back away from the score. Then cut the paper on the second side following the original score line. Neat straight cuts can be made using a straight edge.

The cut edges should be sanded smooth to form clean joints.

Control joints should be set at twelve (12) metres maximum, or at construction joints, whichever is the lesser (refer page 6).

Control Joints

Control joints must be installed in walls and ceilings at a maximum spacing of 12m, or at control/construction joints, whichever is the lesser.

Architectural features, openings, and the like may be used as control joint set out points.

Rondo 'P35' or MBS 'PXJ-30' are suitable control/expansion joints.

Control joints are centrally located across the 15mm minimum gap between adjacent BGC Plasterboard sheets, and the flanges nailed at 300mm centres to the framing behind.

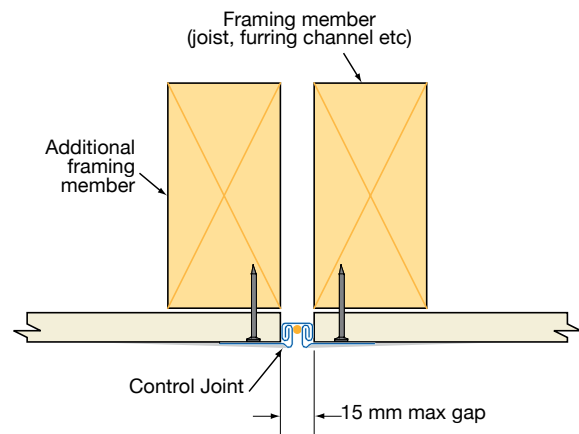

Framing

BGC Plasterboard may be fixed to timber, CFS light steel framing or furring channels, which satisfy the BCA requirements and which have been plumbed true and straight.

Timber framing must comply with the requirement of AS1684 'National Timber Framing Code' and AS1720.1&.2 'Timber Structures' and have a moisture content less than 16% at time of lining.

CFS light-steel framing must be in accordance with AS/NZS4600 'Cold-Formed Steel Structure Code', AS3623 'Domestic Metal Framing' and AS1397.

BGC Plasterboard may be fixed to CFS steel framing not exceeding 1.25mm BMT. Framing members must have a 35mm minimum face width for nail fixing and 32mm for screw fixing.

Steel Frame Application

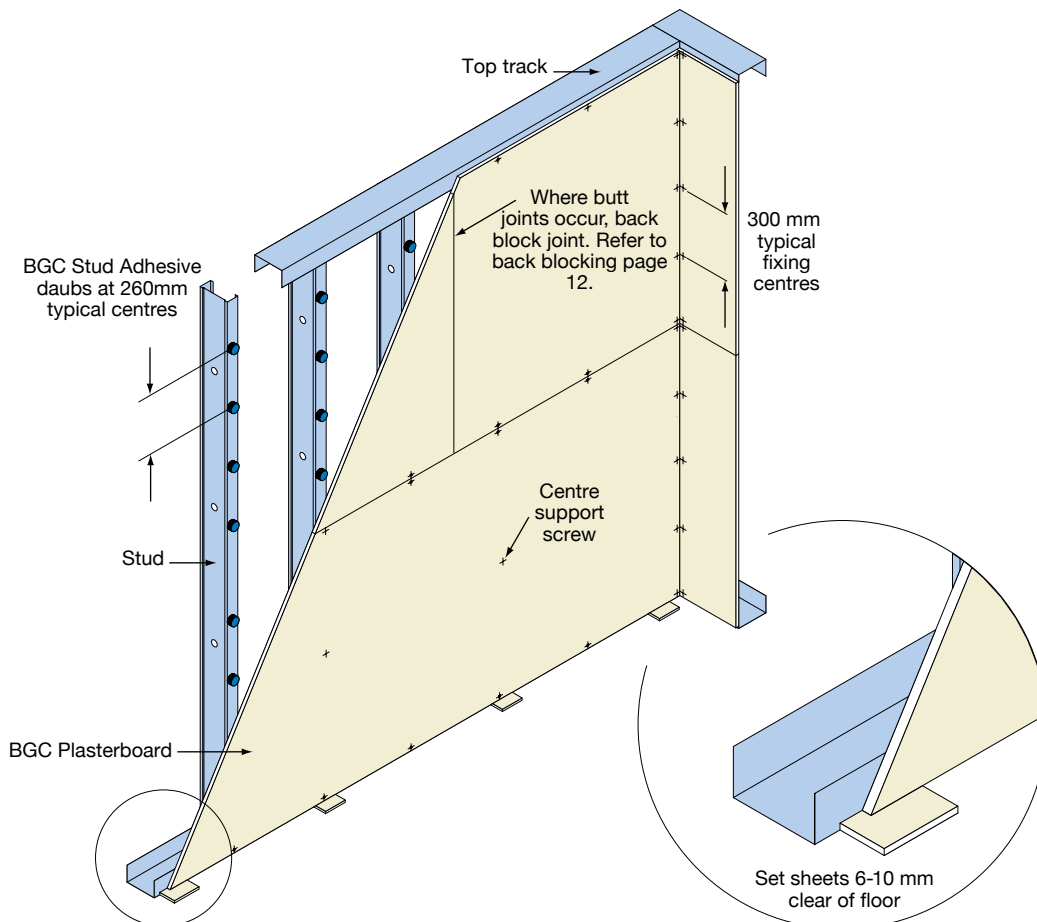

Framing

Frames must be plumbed true and straight, to comply with the degree of finish required of the BGC Plasterboard.

The tolerance deviation over 1.8m spans, along and across members, for 90% of the wall and ceiling framing, shall be as set out in Table 2.

Frame Alignment Deviation – Table 2

LEVEL 3 AND 4		LEVEL 5	
Deviation of 90% of area (mm)	Deviation of remaining area (mm)	Deviation of 90% of area (mm)	Deviation of remaining area (mm)
4	5	3	4

Maximum spacing of framing members depends on the structural requirements for the building, in accordance with AS1170 and AS4055, however the maximum allowable spacing for studs, joists, furring channels or battens shall be as set out in the Table 3.

Spacing of Frame Member – Table 3

THICKNESS (mm) & PRODUCT	APPLICATION	MAX. SPACING OF FRAMING MEMBER (mm)
10 Plasterboard	Walls	600
	Ceilings	450
13 Plasterboard	Walls	600
	Ceilings	600
10 Ceilingboard	Walls	600
	Ceilings	600
10 Water Resistant Plasterboard	Walls	600
	Ceilings	450
13 Water Resistant Plasterboard	Walls	600
	Ceilings	600
13 Fireboard	Walls	600
	Ceilings	600
16 Fireboard	Walls	600
	Ceilings	600
10 Moisture Resistant Flameboard	Walls	600
	Ceilings	450
13 Wet Area Fireboard	Walls	600
	Ceilings	600
16 Wet Area Fireboard	Walls	600
	Ceilings	600
10 Soundboard	Walls	600
	Ceilings	450
13 Soundboard	Walls	600
	Ceilings	600
6.5 Curveboard*	Walls	450
	Ceilings	450
13 Impactboard	Walls	600
	Ceilings	600

Trimmers are to be used where the main structural members change direction and all openings must be framed.

*Refer to the Curveboard brochure for further information on spacing of framing members as this may change depending on the angle of the curve required.

Adhesive, Nails or Screws

BGC Plasterboard may be fixed to the framing with either adhesive and nails or adhesive and screws as appropriate.

Water-based acrylic gypsum plaster adhesives such as BGC Stud Adhesive, which comply with AS2753, are suitable for fixing BGC Plasterboard to both metal and timber framing.

Adhesive fixing is used in conjunction with fasteners, except for wet and tiled areas, fire-rated construction, over vapour-barriers or existing work, where mechanical fasteners, nails or screws only must be used.

The position of daubs of BGC Stud Adhesive 'O' and permanent fasteners 'X' should be as set out as shown in the Table 4.

Position and Number of Adhesive Daubs and Fasteners Across Sheet - Table 4

SHEET WIDTH (mm)	WALL	INTERNAL CEILINGS	EXTERIOR CEILINGS/GARAGES
1200	XOOOOX	XOOXXOOX	XOXOXOX
1350	XOOOOX	XOOXXOOX	XOXOXOX

Ensure that contact surfaces are free from grease, oil, dust or other loose material prior to placing BGC Stud Adhesive daubs (always clean down steel furring before fixing plasterboard sheeting).

Galvanised 2.8mm standard or ring-shank clouts are used to fix the BGC Plasterboard to timber, see Table 5.

Minimum Nail Fastener Length – Table 5

THICKNESS (mm)	SUBSTRATE MATERIAL	
	HARDWOOD	SOFTWOOD
10	2.8mm x 30mm galvanised nail or 2.8mm x 25mm ring shanked nail	2.8mm x 40mm galvanised nail or 2.8mm x 30mm ring shanked nail
13	2.8mm x 30mm galvanised nail or 2.8mm x 25mm ring shanked nail	2.8mm x 40mm galvanised nail or 2.8mm x 30mm ring shanked nail
16	2.8mm x 40mm galvanised nail	2.8mm x 50mm galvanised nail

A full mechanical fastening system may be necessary in regions experiencing high loads on external ceiling areas such as carports, garages and verandahs.

Framing

Needle-point (NP) or self drilling and tapping point (SDP), bugle-head screws are used to fix to CFS light steel framing, and must comply with AS3566, see Table 6.

Minimum Screw Fastener Length - Table 6

THICKNESS (mm)	SUBSTRATE MATERIAL					
	HARDWOOD		SOFTWOOD		STEEL	
	SCREW LENGTH mm	SCREW GAUGE NO.	SCREW LENGTH mm	SCREW GAUGE NO.	SCREW LENGTH mm	SCREW GAUGE NO.
10	25 needle point (see note 1)	6	30 Type W (see note 1)	6	25 S point (see note 1)	6
13	25 needle point (see note 1)	6	30 Type W (see note 1)	6	25 S point (see note 1)	6
16	30 needle point	6	45 Type W	6	20 S point	6

1. Screws used for fixing plasterboard to timber ceiling substrates (hardwood and softwood) shall have a minimum length of 30mm
2. S point screws shall be used for steel thickness less than or equal to 0.75mm base material thickness (BMT)
3. Drill point screws shall be used for steel thickness greater than 0.75mm base material thickness (BMT)

Note: When fixing into preservative treated timbers, Class A AS 3566 coatings of screws and nails are to be used.

Fixing to Framing

Walls

Daubs of BGC Stud Adhesive, 25mm diameter x 15mm high are positioned in the pattern as shown in Table 4, spaced at a maximum of 300mm and a minimum of 200mm.

BGC Stud Adhesive must not be used at wall-to-wall and wall-to-ceiling junctions, around openings, butt joints or fastener points.

BGC Plasterboard is placed horizontally along each wall. Sheets to be packed 6-10mm from floor and fastened along the top recessed edge at each stud or furring channel.

The sheets are then pressed firmly against the studs and temporary fastened midway across the sheet at every second stud or furring channel.

Next, fasten the other recessed edge at each stud, or furring channel.

Fasteners must not coincide with BGC Stud Adhesive daubs, and fasteners should be kept to a minimum distance of 200mm from adhesive daubs.

Fasteners around openings should be placed at a maximum spacing of 300mm centres. Allow at least 24 hours for the adhesive to set.

Timber Frame Application

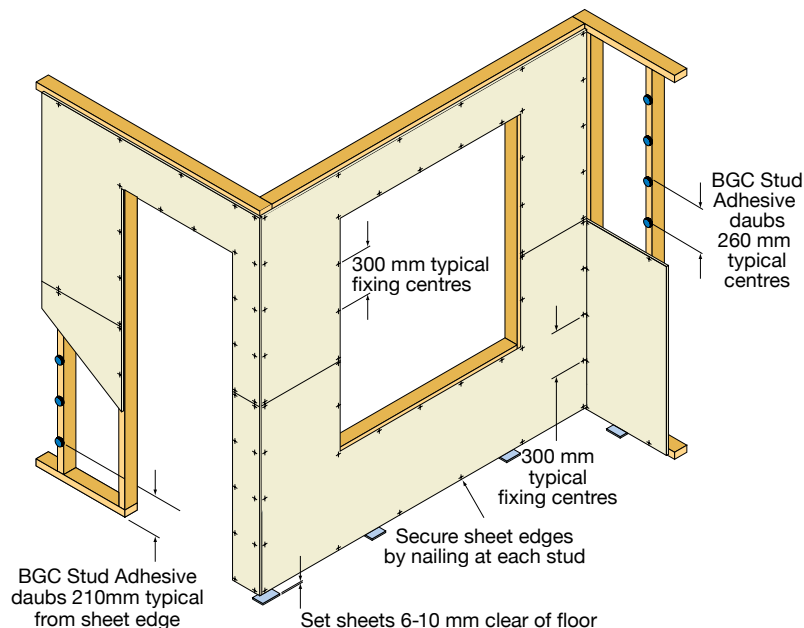

Interior Ceilings

BGC Stud Adhesive, 25mm dia. x 15mm high, are positioned in the pattern as shown in Table 4, spaced at maximum of 250mm and minimum of 200mm centres.

BGC Stud Adhesive must not be used at wall-to-wall and wall-to-ceiling junctions, around openings, butt joints or fastener points.

BGC Ceilingboards are placed at right angles to the ceiling joists, battens or furring channels, and fastened along one recessed edge at each joist, batten or furring channel.

Next, press the sheets firmly against the framing, and fix two nails (for timber framing) or one screw (for CFS steel framing), along the centre of the sheet at each framing member.

Then, fasten off the sheets along the other recessed edge, at each framing member. Fasteners must not coincide with BGC Stud Adhesive daubs, and fasteners should be kept to a minimum distance of 200mm from BGC Stud Adhesive daubs.

Where allowed, fasteners at butt joints and around openings should be placed at a maximum spacing of 150mm for nails and 200mm for screws.

Allow at least 24 hours or 48 hours in slow drying weather, for the BGC Stud Adhesive to cure.

Ceiling Sheet Application

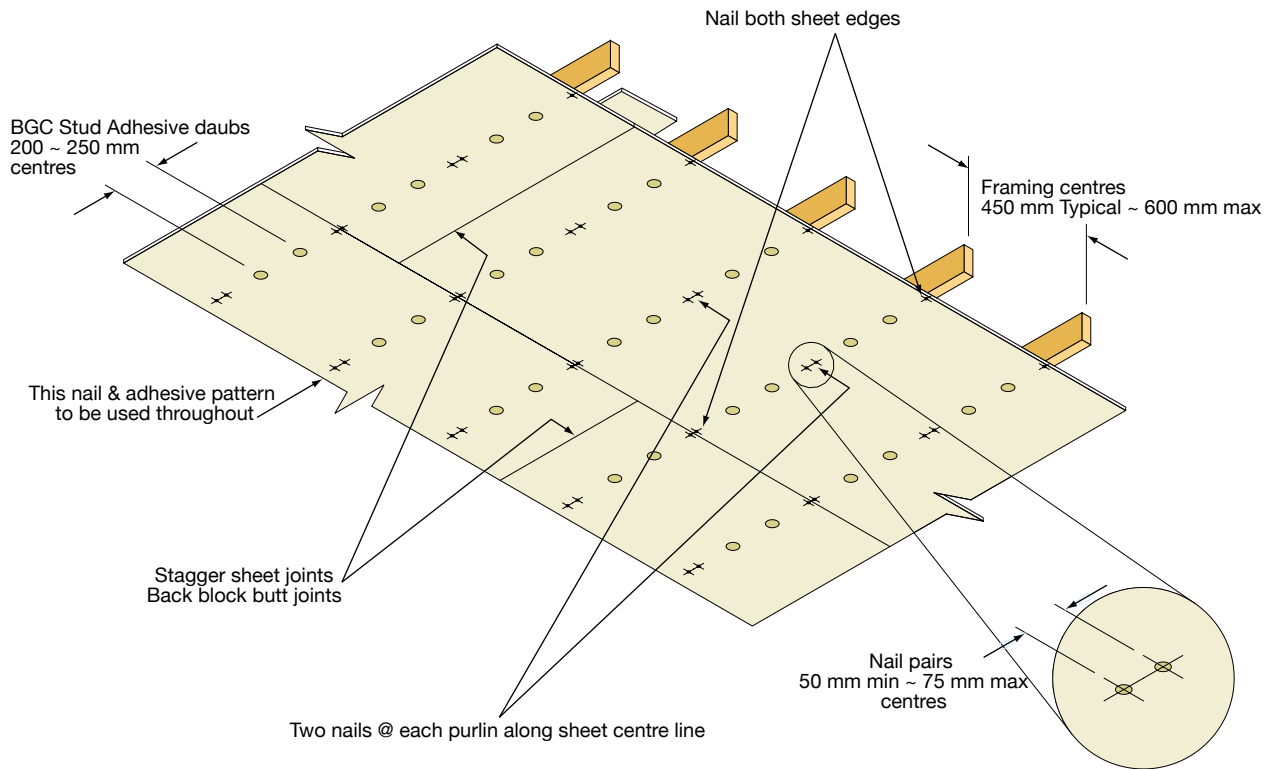

Exterior Ceilings

An exterior ceiling covers areas outside the main enclosed living area of a house such as entertainment areas (Alfresco), carports and garages.

The different environments of exterior ceilings are often severe and can be effected by:

- The generally constant high humidity,
- The climate of the region,
- Wind loads,
- Garage Roller Door Vibration,
- Insufficient perimeter support.

To overcome potential problems in these areas it is important to consider the following points:

- The correct choice and installation of lining materials, fasteners, jointing and coating materials, designed to suit the environments,
- Correct placement and installation of battens and installation methods,
- The design and detail of the structural components and their protection from moisture,
- Final paint decoration.

Condensation

Surface condensation and wind loads can be the main causes of lining board and jointing system failure. Insufficient protection can lead to the plasterboard distorting as well as potential mould attack.

Use sarking or foil backed insulation underneath metal roofing as metal is more susceptible to condensation build up than roofing tiles.

It is important that ceiling cavity areas are well ventilated to prevent condensation build up. The installation of eave and gable vents, roof ventilators etc. can assist in this by providing permanent cross flow ventilation.

Building materials and systems may be adversely affected by these severe environmental and physical conditions, which if not installed correctly can lead to ceiling failure and or collapse.

Plasterboard Materials

BGC 10mm and 13mm Water Resistant Plasterboard, 10mm Moisture Resistant Flameboard, 10mm Ceilingboard and 13mm Plasterboard may be used as suitable lining materials in exterior ceiling areas.

Installation

All perimeters must have appropriate framing/noggings etc. In order to support all sheet edges. Perimeters to be screw fixed only at 300mm centres. The perimeter may be fixed out with timber noggings, metal plasterers angle (Rondo P18) or equivalent.

Plasterboard sheets fixed to exterior ceilings must be either mechanically fixed with appropriate screws or using the 1/3 spacing method using appropriate screws and stud adhesive as per AS/NZS 2589:2007. Paper tape must be used in conjunction with setting type base products in the recessed joints. Base and topping to comply with ASTM C475. All trowelled joints to be back blocked in accordance with AS/NZS 2589:2007.

Plasterboard sheets to have a minimum 6-10mm space from perimeter walls.

Fascia boards/perimeter beams should continue at least 20mm below the bottom of the plasterboard ceiling or the perimeter wall/ceiling trim.

Framing centres to be at a maximum of 450mm.

Ceiling Areas

For long runs of sheets and or large sheet areas, with set joints, movement control (expansion) joints must occur at maximum prescribed distances.

Generally, set joint areas should not exceed 20m², with a maximum distance of 3.6m across the sheets and a maximum of 5.4m along the sheets.

1/3 Fixing

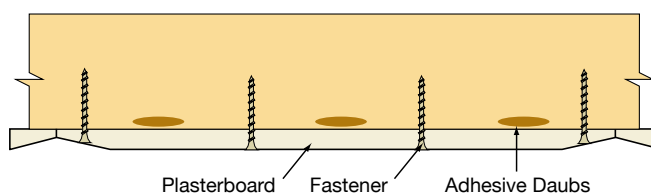

Garage Areas

Roller/tilt door operation can result in differential movement due to vibration resulting in positive joint cracking and adhesive breakdown/failure.

While the finish and appearance of these areas remains the same as ceiling in habitable areas additional details are required.

BGC Plasterboard recommends the use of Water Resistant Plasterboard with 1/3 fixings.

- Screw and glue fix only.
- Back block all joints.
- Use of proprietary branded quality sealer prior to painting.
- Use wet area base coats in jointing system.

Considerations

Before lining the building it is prudent to consider the following design and construction issues:

- Consideration must be given to the framing, this may vary throughout Australia especially in high wind and coastal areas.
- It is highly recommended to batten out the ceiling with Rondo 16mm metal battens or 16mm Furring Channel or 28mm Furring Channel or equivalent. These are to be fixed on the appropriate direct fix clips.
- High-pressure differentials across a wall, may cause the wall to bend and move.

Ensure that wall and ceiling areas do not exceed maximum allowable areas, heights or lengths, and provide movement and or relief control joints where necessary.

- Decoration is as important as the plasterboard installation and is vital in protecting both plasterboard and the set trowelled areas. The surface of the installed plasterboard ceiling should be decorated with an approved exterior grade paint. Please refer to your paint manufacturer for the appropriate grade required.

Alfresco Coffered Detail

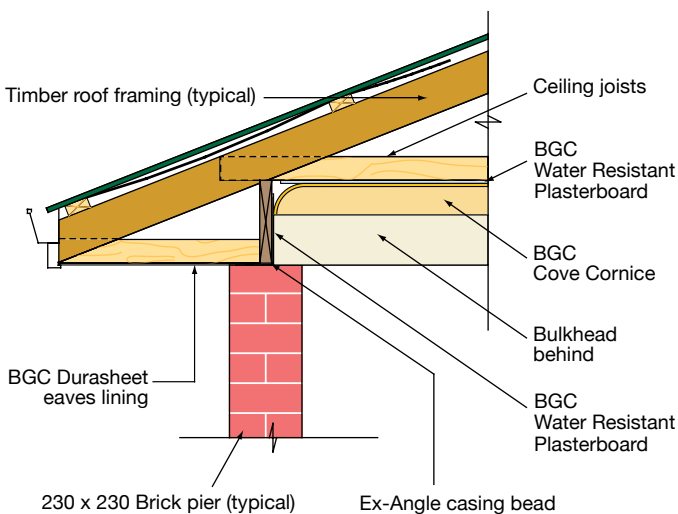

Eaves Details - Casing Bead

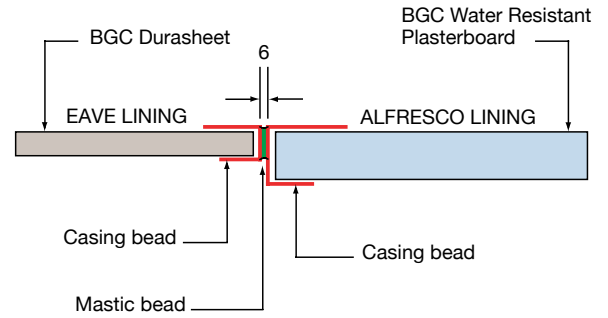

Timber Stop

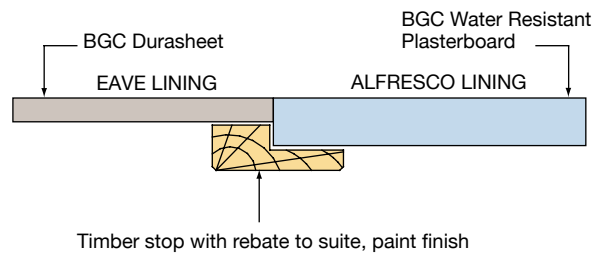

Back Blocking

Back blocking is used to reinforce unsupported butt or recessed joints and must be positioned midway between supporting members, in ceilings and walls.

Back blocking must be used in open areas of ceilings (back of recessed joints) with 3 or more joints and where there is a likelihood of excessive shrinkage and movement in the structure.

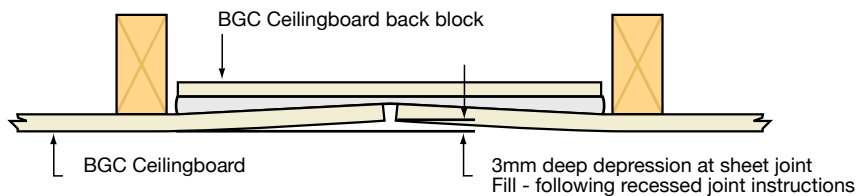
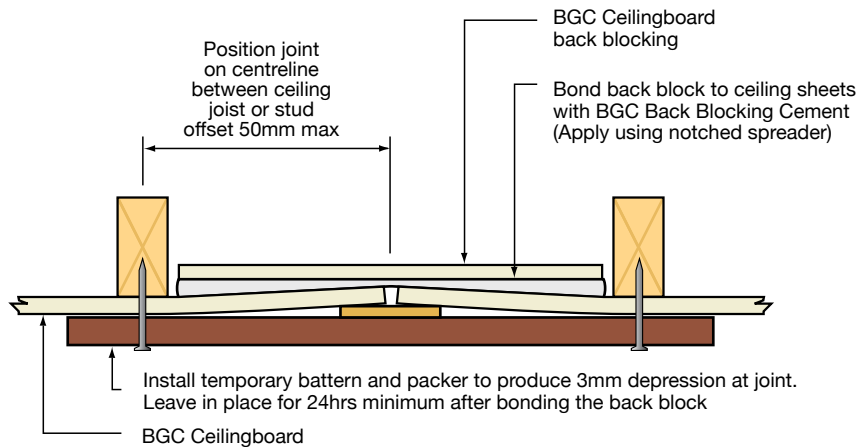

Back Blocking Procedure For Recessed Edge Joints

(a) Cut back blocks at least 200 mm wide and long enough to fit between the framing members with a gap not greater than 30 mm at each end.

(b) Apply BGC Back Blocking Cement over the full face of the back block. A notched spreader providing 6 mm x 6 mm beads at approximately 20 mm centres at right angle to the joint would be satisfactory.

(c) Fix the plasterboard to framing members.

(d) Place back blocks centrally along the full length of the board edge.

(e) Immediately after the back blocks are in place, fix the next sheet.

Alternatively, ceilings back blocks may be cemented into position from above the ceiling after the sheets have been fixed and before they are flush jointed.

Back Blocking Procedure

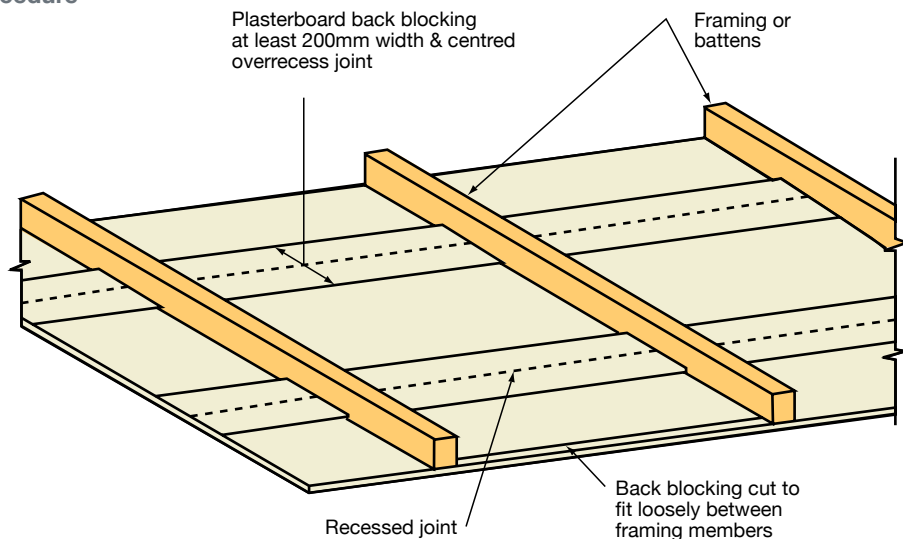

Jointing Application

Paper tape joints produce stronger and more enduring results than those that are set with fibreglass tapes.

BGC Plasterboard recommends the use of paper tapes.

- Self-adhesive paper tapes should not be used.
- Where fibreglass tape joints are used, they must be back blocked before the joints are set (in accordance with the instructions set out in Back Blocking, page 12).

Tape & First Coat

Apply the BGC Base Coat bedding cement to fully fill the recess of the joint.

Centrally bed the perforated paper tape into bedding coat and remove any air bubbles. Apply additional cement and cover lightly with BGC Base Coat.

Stop-up all fixing points and apply BGC Base Coat to any damaged areas.

Allow the BGC Base Coat to set and dry for a minimum of 24 hours in damp or humid conditions or 1 hour for setting type cements (or as per compound manufacturer's recommendation).

Tape & First Coat

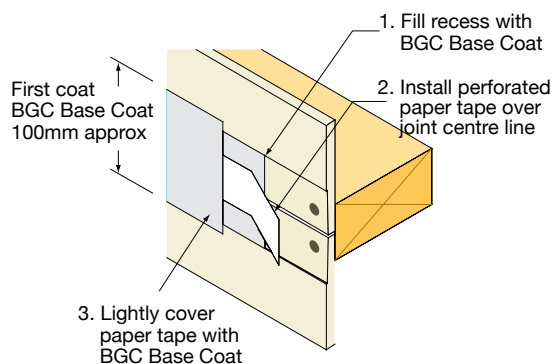

Second Coat

Lightly sand the first coat.

Check the Level of Finish required in the architects' specification, before applying the second coat as detailed in Plasterboard Finish Selection (page 4).

Apply a second coat of BGC Base Coat 180mm wide over the joints, making sure to feather out the edges.

Apply a second coat to all fasteners and damaged areas, feathering out by about 25mm.

Allow the second coat to set and dry for a minimum of 24 hours or 1 hour for setting type cements (or as per compound manufacturer's recommendation).

Second Coat

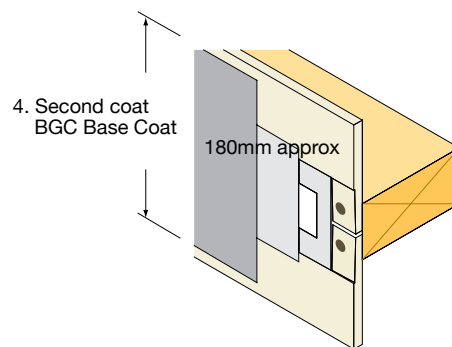

Third Coat

Lightly sand the second coat.

Apply a thin finish coat of BGC Top Coat centrally over second coat, after it has set and hardened. Dampen the outer edges of the finish coat, with a sponge to feather out the BGC Top Coat about 280mm approx wide.

Apply a thin final coat of BGC Top Coat over all fasteners and damaged areas.

Third Coat

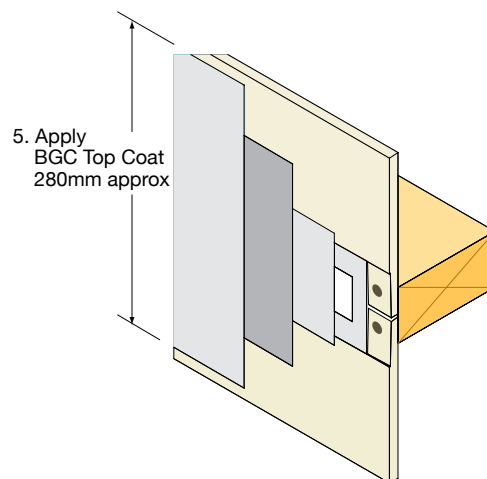

Sanding and Finishing

Allow the BGC Top Coat to dry at least 24 hours.

Lightly sand smooth with 150 grit paper or with 220 sanding mesh.

Wipe off excess dust with a slightly damp cloth.

Sanding and Finishing

Allow 24 hours min drying time then lightly sand joint

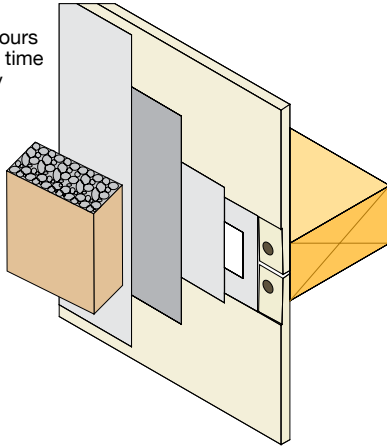

BGC Plasterboard will perform to the architects' specification and the Australian Building Codes, provided all procedures are followed as per the compound manufacturers' specification.

Internal Corner Detail

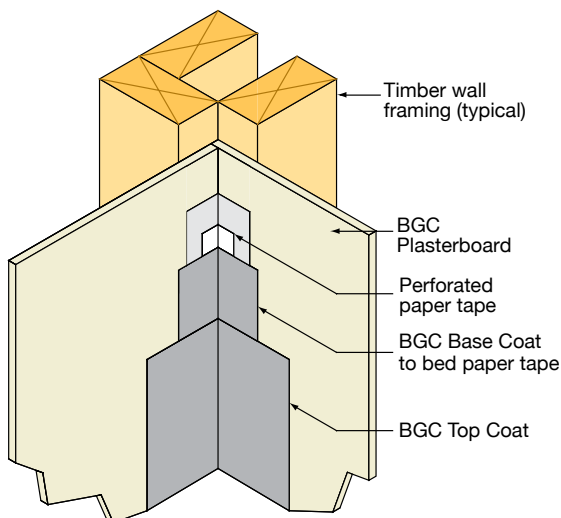

External Corner Detail

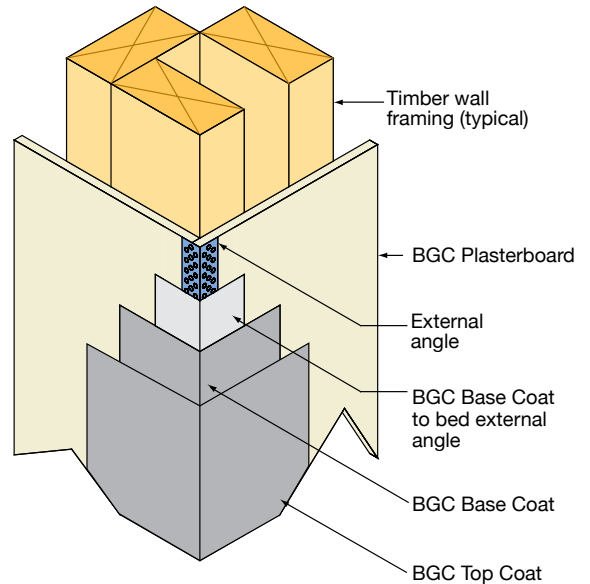

Decoration

BGC Plasterboard does not recommend spray painting to achieve level 4 or higher finish.

Ensure all stopping of joints and nail holes is completed to AS/NZ 2589:2007.

Brush down area prior to painting to ensure board is free from sanding dust.

Roller apply a proprietary branded quality sealer, to the entire sheet area including joints, followed by two coats of full weight flat acrylic paint.

Choice of colour should be considered carefully - darker colours will exacerbate any defects and highlight any imperfections.

Where high humidity is of concern, ensure the chosen painting system will protect joints from moisture absorption.

Cove Cornice

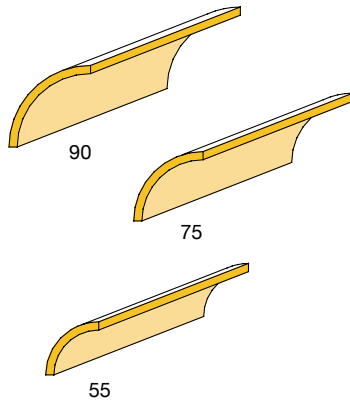

BGC Plasterboard Cove Cornice is designed to give a clean continuous line at the junction of walls and ceilings, and can be used with confidence on both Plasterboard lining and cement plastered walls alike.

BGC Plasterboard Cove Cornice is made of a plaster core with paper face to complement BGC Plasterboard and Ceilingboard. Cove Cornice should be fixed using BGC Cornice Cement with few special tools required.

The use of a mitre box and hand saw for cutting internal and external corner mitres is recommended.

Cove Cornice Sizes - Table 7

SIZE (mm)	LENGTH				
	3000	3600	4200	4800	5400
55	X	X	X	X	X
75	X	X	X	X	
90	X	X	X	X	X

Decorative Cornice

The Decorative Cornice range from BGC Plasterboard adds the finishing touch to the interior décor of your new home or renovation.

Esperance provides a timeless design suiting many different styles of home. The soft undulation of the curve provides a stylish finish to any room.

For the bolder finish, don't look any further than the Albany decorative cornice. With dramatic steps and bold curves, Albany creates an eye catching feature in a room.

Decorative Cornice

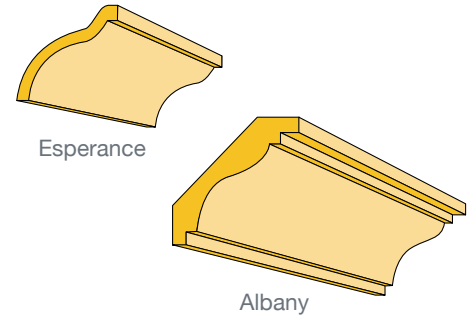

Decorative Cornice Sizes - Table 8

DESIGN	SIZE (mm)	LENGTH mm
		4800
Esperance	75	X
Albany	95	X

Fixing

Clean down area where cornice is to be applied, remove any excess render or loose material.

Mark a guide line to suite the bottom edge of the cornice (90, 75 or 55 down) and pre-cut lengths as required.

All corner joints, internal and external, are to be mitred.

Where butt joints are unavoidable, ensure both ends are prepared to align accurately.

Apply (butter) a 10mm bead of cornice cement to both long edges and ends of the cornice.

Locate cornice to guide lines and temporarily block as required.

Fill mitres, cleaning off excess cement as you go.

Remove temporary blocking after BGC Cornice Cement has set.

Apply second topping coat to mitres and joints as required. Note: only ever butter one length at a time and install immediately.

Contact surface may require damping down prior to fixing cornice, depending on drying conditions.

To contact your nearest BGC stockist, please call:

Adelaide
Telephone
08 8250 4962

Brisbane
Telephone
07 3711 4744

Melbourne
Telephone
03 9392 9444

Perth
Telephone
08 9374 2900

Sydney
Telephone
02 9632 2100

New Zealand
Telephone
0011 64 9264 1457

bgc.com.au/plasterboard

BGC Plasterboard is a proud Australian owned manufacturer of Plasterboard products.

BGC has state-of-the-art manufacturing facilities in Perth and distribution centres in all states of Australia and in New Zealand.

Our distribution network ensures that our entire product range is readily available in all states of Australia.

BGC has a team of technical specialists who can assist with all specification and design information.

BGC provides builders, developers and architects with a range of design alternatives and innovative products, such as:

- **Ceilingboard™** – designed for interior use providing a flat, blemish free, monolithic, smooth surface ready for decorating and is ideal for all internal ceiling applications, residential and commercial where cost effectiveness is paramount.
- **WR Plasterboard** – primarily developed for wet area walls in residential and commercial buildings but is also ideal for Verandas, garages and alfresco ceilings.
- **Fireboard™** – designed for use where fire systems are specified in residential and commercial buildings. Fireboard™ delivers the required Fire Resistance Level whilst maintaining a flat, blemish free surface suitable for decoration.
- **Soundboard™** – is high density plasterboard that has been specifically designed to greatly reduce unwanted noises that can be heard from one room to another through walls and ceilings.
- **Wet Area Fireboard™** – has been developed specifically for use in wet areas where a fire resistance level is specified.
- **Moisture Resistant Flameboard™** – has been developed specifically designed for use in fire risk areas where no FRL is required.
- **Compounds** – BGC plasterboard has developed a range of plasterboard compounds to aid in the fixing of our various products.
- **Cove Cornice** – provides a clean, continuous line at the junction of wall and ceilings. Three profile sizes are available to suit all applications.



Quality
Endorsed
Company

Safe working practices - Please wear a P1 or P2 mask and safety goggles (approved to AS/NZW1337 standards) whilst cutting or installing BGC Plasterboard. BGC Plasterboard can be safely handled during unloading or stacking without the use of these precautions.
Cleaning up - Always wet down your work area when cutting BGC Plasterboard, to ensure that dust is managed. Dispose of any vacuumed dust with care and using containment procedures.