



**For More Information
BGC Branch Offices
www.bgcplasterboard.com.au**

Head Office Perth WA

290 Bushmead Road, Hazelmere, Western Australia, 6055
Telephone: (08) 9374 2900 Facsimile: (08) 9374 2901
Postal Address: P.O. Box 1948, Midland DC, Western Australia 6936

Adelaide

978 Port Road, Albert Park, South Australia, 5014
Telephone: (08) 8347 0844 Facsimile: (08) 8347 3122

Melbourne

200 - 238 Maidstone Street, Altona, Victoria 3018
Telephone: (03) 9392 9444 Facsimile: (03) 9392 9404

Sydney

32 - 34 Pine Road, Yennora, New South Wales 2161
Telephone: (02) 9632 2100 Facsimile: (02) 9632 2144

Brisbane

39 Gardens Drive, Willawong, Queensland 4110
Telephone: (07) 3711 4744 Facsimile: (07) 3711 4666

Warranty

BGC warrants its products to be free from defects caused by faulty manufacture or materials. If any of its products are so defective the Company will at its option, repair or replace them, supply equivalent replacement or reimburse the purchase price.

This warranty shall not apply to any loss or consequential loss suffered through or resulting from defects caused by faulty manufacture or materials.

The propriety joint and coating systems are outside the control of BGC, therefore the independent joint and coating manufacturers must give all warranties for the jointing system performance.



Produced by BGC Plasterboard ABN 62 005 736 005 020
™ Denotes a trademark owned by BGC Australia Pty Ltd.
Supersedes all previous publications.

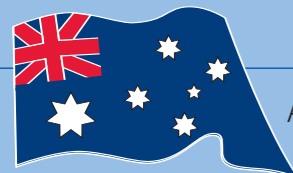

Australian Owned
& Manufactured

BGC A Product of Advanced Technology

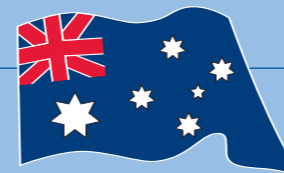

BGC Performance Based Products
BGC Water Resistant Plasterboard

BGC (Australia) Pty Ltd

BGC (Buckeridge Group of Companies), has developed into a diversified industrial group with an annual turnover that makes it one of Australia's largest, privately - owned companies.

Its wide range of operations includes manufacturing, residential and commercial building, property ownership and management, contract mining, bulk haulage, quarrying and insurance. It is the largest residential building company in Western Australia, and one of the biggest in the nation.

A decentralised management structure allows each of the autonomous business units the flexibility to make individual business decisions, along with the knowledge and backing of sound corporate experience.

The West Australian - based group has operations in each of Australia's mainland states with an international reach that extends to New Zealand and South East Asia. BGC is also exporting its products to growing markets in both Singapore and Hong Kong.

BGC stands by its quality, commitment and capacity to provide outstanding results for any building activity.

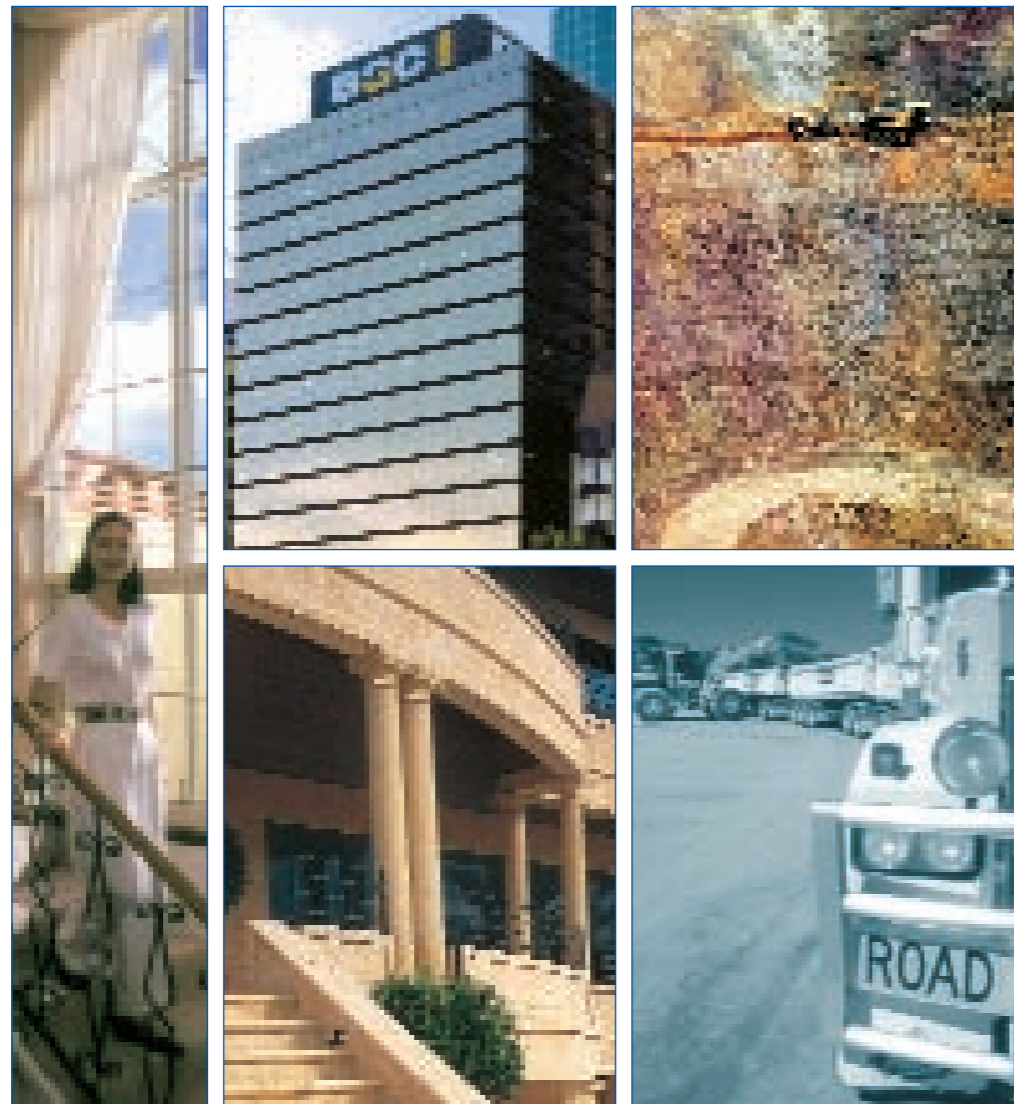

Contents

Introduction	3
Key Benefits	3
Level of Finish	3
Early Fire Hazard Indices	3
Availability	3
Installation	4
Tiled Areas	5
Pre-Formed Shower Base	5
Insitu Shower Tray	5
Shower Over Bath	6
Structural Movements and Control Joints	7
Jointing	8
Australian Standards - Wet Areas	10

Introduction

BGC Water Resistant (WR) plasterboard complies with the requirements of AS2588 'Gypsum Plasterboard', (refer CSIRO Test Report DTS 713).

BGC Plasterboard designed and developed WR Plasterboard for wet area walls, in residential and commercial buildings, such as bathrooms, laundries, toilets and cleaning room areas.

BGC WR plasterboard is to be installed in accordance with AS 2589.1;1997 "Gypsum Plaster Linings in Residential and Light Commercial Construction - Application and Finishes" and as detailed in AS 3740:2004 "Waterproofing of Wet Areas within Residential Buildings".

BGC WR Plasterboard has a light-blue fungal resistant multi-layered facing board for easy identification. It is available in 10mm and 13mm thicknesses with recessed edges, ready for taping and jointing with proprietary water resistant stopping and setting compounds.

BGC WR Plasterboard has a low absorption core, eliminates the probability of water wicking, therefore preventing possible damage to the supporting structure and wall finishes.

Key Benefits

- Cost effective, drywall wet-area lining system.
- High serviceability performance board.
- Dimensionally stable substrate for tiled wall finishes.
- Ready for decorative paint and thin cover finishes.

Plasterboard Finish Selection

The selection of plasterboard finish in wet areas depends on the desired tiled surfaces and other wall decorations required. Generally, use Class 3 and 4 finishes in wet areas, as detailed in AS 2589.1-1997.

Where tiles are used, the finish can be of a lower standard and where other decoration is required, the standard is higher. BGC Plasterboard recommends the architect's specifications for the level of finish required.

Early Fire Hazard Indices

BGC WR Plasterboard complies with AS 1530.3:1999

- Ignitability - 0
- Spread of Flame Index - 0
- Heat Evolved Index - 0
- Smoke Developed Index - 4

Availability

BGC WR Plasterboard is available in 10mm and 13mm thicknesses, 1200mm and 1350mm wide and in various lengths.

BGC Plasterboard ensures that the range of stock sheet sizes listed are available, however variations may occur in some states.

Table 1

Lengths

Thickness	Width	2400	2700	3000	3600	4200	4800	6000
10mm	1200	✓	✓	✓	✓	✓		✓
	1350	✓		✓	✓	✓	✓	
13mm	1200	✓		✓	✓	✓		
	1350			✓	✓	✓		

Installation

Install and fix BGC WR plasterboard sheets horizontally to minimise the number of joints and to minimise light reflections across the joints.

Cut the BGC WR Plasterboard from the face and snap back away from the score, then cut the back paper face toward the front face.

Use a straightedge for neat straight cuts.

Framing

Install and fix BGC WR plasterboard to timber or Cold Formed Steel (CFS) framing or furring channels, which satisfy the BCA requirements and which have been plumbed true and straight.

NOTE: Timber shall be kiln dried with a moisture content below 16%.

Prior to installing and fixing BGC Water Resistant Plasterboard, ensure that the preceding trades have certified, that -

- Structural movement will not occur (or is minimised) at wall-to-wall and floor-to-wall junctions. Refer Figure 7.
- All noggings, trims and the like, are correctly installed and fixed for the bath, basins and other fixtures (Noggings are spaced at 600mm maximum centres for 10mm plasterboard and 800mm maximum centres for 13mm plasterboard).
- All perimeters, corner and control joint flashings are in place and correctly installed.

Fixing

Fix BGC WR Plasterboard sheets horizontally to wall framing and or furring channels, with the bottom sheets first, at 10mm clear of the finished floor.

Set out sheets around all wall openings, with cutouts 200mm horizontally and 250mm vertically, to prevent corner cracking.

For untiled walls space fasteners at 600mm maximum centres on internal studs and at 150mm for internal and external corners. See Figure 4.

Press sheets firmly against the frame facing and fasten along one recessed edge at each framing member.

For all wet areas fasten sheets with corrosion resistant Class 3, or better screws, which comply with AS 3566: Screws – Self-drilling – For the Building and Construction Industry.

For timber-framing plasterboard nails must comply with AS 2334; 1980 Steel Nails - Metric series and have a minimum Class 3 or better corrosion resistance.

BGC Plasterboard recommends the use of screw fasteners instead of nails.

Table 2
Minimum Screw Fastener Length and Type

Sheet Thickness	CFS Steel up to 0.55 BMT	CFS Steel 0.75 to 1.1 BMT
10 mm	6-9 x 25 NP	6-18 x 25 SDP
13 mm	6-9 x 30 NP	6-18 x 30 SDP

NOTE: When fixing into preservative treated timbers, Class 3 AS 3566.2-2002 coatings of screws and nails are to be used.

NOTE: Do not fix BGC WR Plasterboard with adhesives.

Figure 1 - Sheet Set Out Untiled Areas

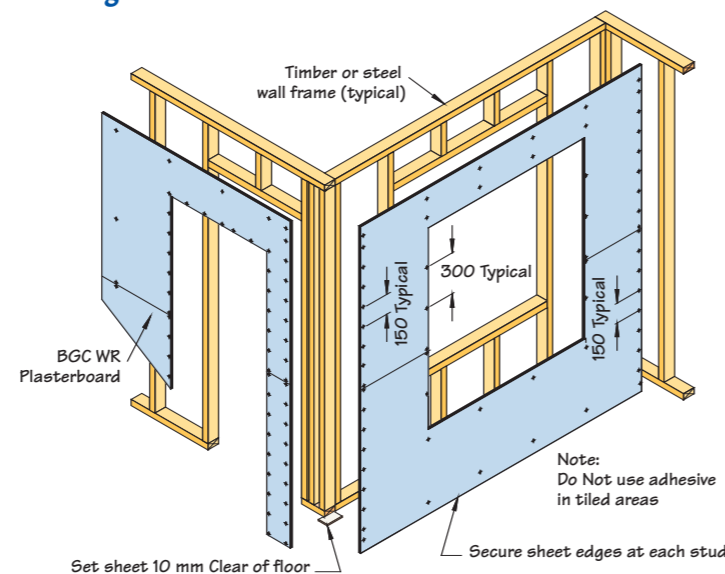

Table 7 Continued...

Vessels or area where the fixture is installed	Requirements for elements				Figure No.
	Floors & horizontal surfaces	Walls	Wall junctions & joints	Penetrations	
Unenclosed	Waterproof entire shower area	Waterproof to 150mm min. above the shower floor substrate or 25mm min. above the maximum retained water level and the remainder to be water resistant to a height of 1800mm min. from finished floor level	Waterproof internal and external corners and horizontal joints to a minimum height of 1800mm above the floor level with a minimum width of 40mm either side of junction	Seal all penetrations	13
Areas outside the shower area for concrete and compressed fibre cement sheet flooring	Water resistant to entire floor	N/A	Waterproof all wall to floor junctions, where a flashing is used the horizontal leg shall be a minimum of 40mm	N/A	13
Areas outside the shower area for timber floors including particleboard, plywood and other flooring materials	Waterproof entire floor	N/A	Waterproof all wall to floor junctions, where a flashing is used the horizontal leg shall be a minimum of 40mm	N/A	
Areas adjacent to baths and spas* for concrete and compressed fibre cement sheet flooring	Water resistant to entire floor	Water resistant to a height of 150mm min. above vessel and exposed surfaces below vessel lip to floor level*	Seal edges for extent of vessel and junction of bath enclosure with floor. Where the lip of the bath is supported by a horizontal surface this area shall be waterproof for showers over bath and water resist for all other cases	Seal all tap and spout penetrations where they occur in a horizontal surface	
Areas adjacent to baths and spas* for timber floors including particleboard, plywood and other flooring materials	Waterproof entire floor	Water resistant to a height of 150mm min. above vessel and exposed surfaces below vessel lip to floor level*	Seal edges for extent of vessel and junction of bath enclosure with floor. Where the lip of the bath is supported by a horizontal surface this area shall be waterproof for showers over bath and water resist for all other cases	Seal all tap and spout penetrations where they occur in a horizontal surface	

BGC Plasterboard wishes to acknowledge & recommend the 'Australian Standards'.

Table 7 Continued...

Vessels or area where the fixture is installed	Requirements for elements				Figure No.
	Floors & horizontal surfaces	Walls	Wall junctions & joints	Penetrations	
Insert baths	N/A for floor under the bath Waterproof entire shelf area, incorporating a waterstop under the bath lip and project a minimum of 5mm above the tile surface	N/A for wall under the bath Waterproof to 150mm above the lip of the bath*	N/A for wall under the bath*	Seal all tap and spout penetrations where they occur in a horizontal surface	13
Walls adjoining other vessels (e.g., sink, basin or laundry tub)	N/A	Water resistant to a height of 150mm min. above vessel if the vessel is within 75mm min. of the wall	Where the vessel is fixed to a wall, seal edges for extent of vessel	Seal all tap and spout penetrations where they occur in a horizontal surface	
Laundries and WCs	Water resistant to entire floor	Seal all wall to floor junctions with a skirting or flashing to 25mm min. above the finished floor level, sealed to the floor	Waterproof all wall to floor junctions, where a flashing is used the horizontal leg shall be a minimum of 40mm	N/A	
Bathrooms and laundries requiring a floor waste in accordance with Volume One of the BCA	Waterproof and drain entire floor	N/A	Seal all wall to floor junctions with a skirting or flashing to 25mm min. above the finished floor level, sealed to the floor	Waterproof where through the floor, otherwise N/A	

LEGEND: N/A - Not Applicable *If a shower is included in a bath, refer to the requirements for shower area walls and penetrations † Does not apply to joinery fittings such as vanities

Figure 15

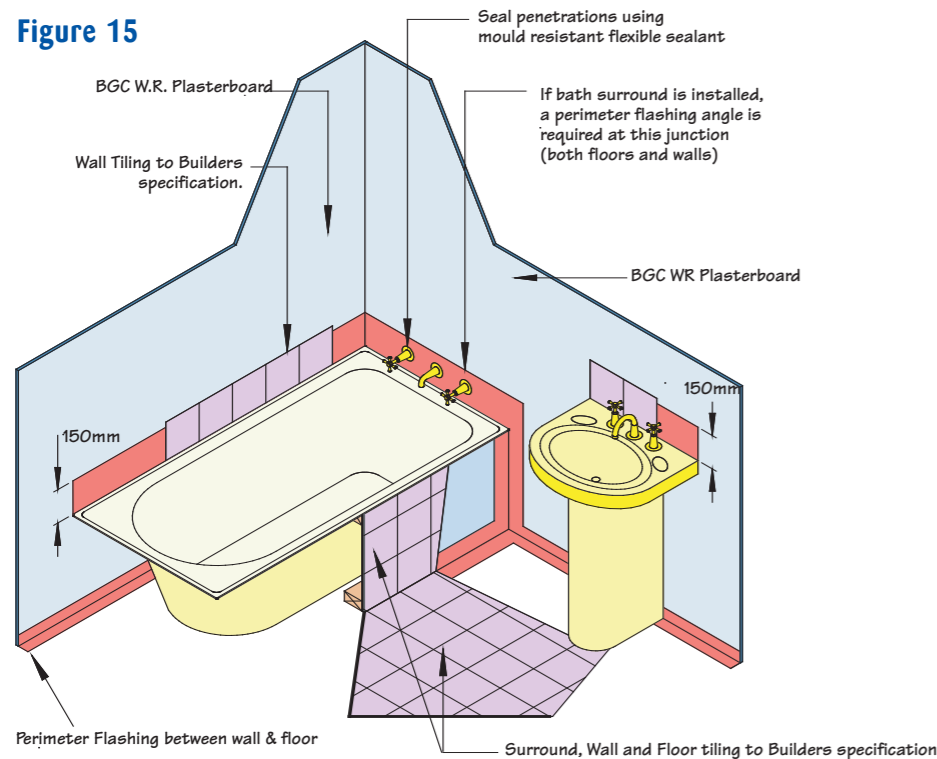

Tiled Walls

Position fasteners between 10mm and 16mm from the edge of the sheets at the correct spacing to carry the loads of the tiles.

For walls with tiles 6.5mm thick or 12.5 kg/m² or less, space fasteners at 200mm maximum centres on the intermediate studs and at 150mm on internal and external corners, butt joints and around openings.

Where tiles are greater than 6.5mm thick or 32 kg/m², space all fasteners at 100mm maximum centres in the centre of sheets, on internal and external corners, butt joints and around openings

Tile adhesive should be compatible with the waterproofing membrane.

Pre-Formed Shower Base and External Shower Tray

Preliminary work and detail fixing out is similar for external shower trays and preformed shower bases, as shown in Figure 2.

Install and fix perimeter-flashing angles, at the wall/floor junction and preformed shower bases or external shower trays, prior to fixing WR plasterboard lining.

Cut and install PVC corner angle, down inside the preformed shower base; Figure 8 and fasten to framing at 600mm centres, in a staggered pattern.

Seal the lower edge of WR plasterboard sheets, whether cut or not, with a proprietary wet-area acrylic sealant to prevent potential moisture wicking.

Figure 2

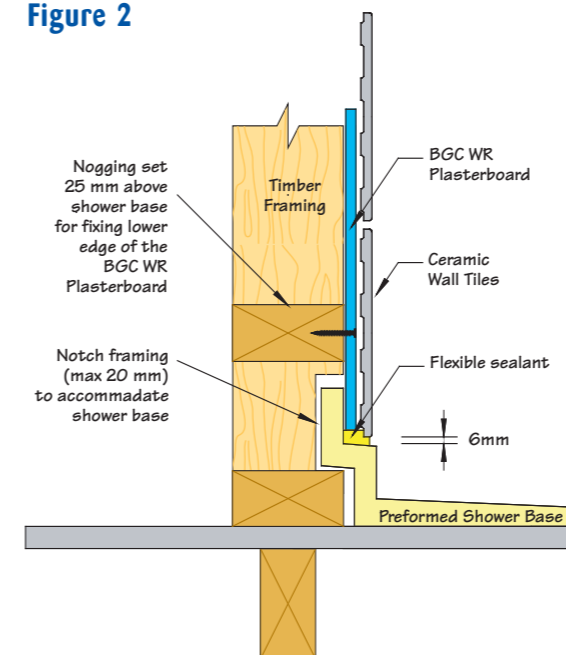

Install and fix sheets to the wall framing 6mm clear of the shower tray up-stand; See Figure 2 and of the mortar bed in the external shower tray.

Caulk the bottom edge of the sheets and the shower base or the mortar bed and around plumbing fixtures with a flexible sealant. See Figures 2 & 3.

Penetrations

The WR Plasterboard must be cut out to leave a 6 mm gap all round the fixture. This gap must be filled with a mould resistant flexible sealant.

BGC recommends using a hole saw to make a neat cut out for fittings such as taps, shower roses etc.

Additional framing must be installed as required to properly support all fixtures.

Figure 3 - Sealing Penetrations

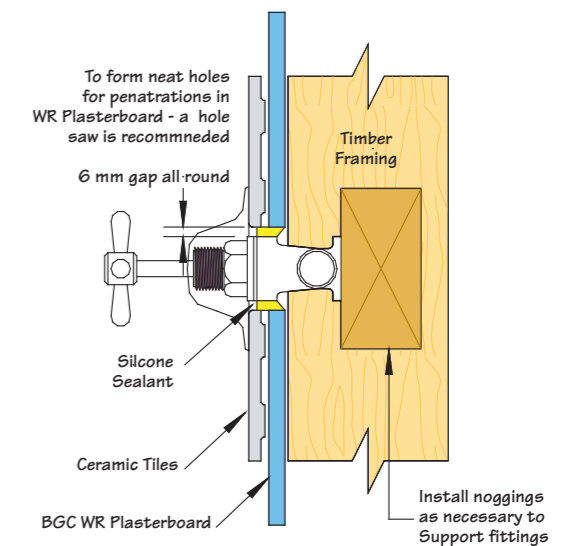

In situ Shower Tray

Install and fix perimeter-flashing angles, at the wall/floor junction.

Cut and install PVC corner angle and fasten to framing at 600mm centres, in a staggered pattern.

Seal the lower edge of water resistant plasterboard sheets, whether cut or not, with a proprietary wet-area acrylic sealant to prevent potential moisture wicking.

Install and fix sheets to the wall framing, as outlined previously, 6mm clear off the floor.

Form a bond-breaker with closed-cell foam backing rod and masking tape at the bottom edge of the Plasterboard at wall/floor junction, as shown in Figure 4.

Insitu Shower Tray cont...

Caulk around plumbing penetrations and up the internal corners of the shower with flexible sealant.

Apply a proprietary liquid membrane material to the face of the plasterboard and floor to form an insitu internal shower tray.

Follow the membrane manufacturers' instructions.

Apply the membrane to the vertical corner to a minimum height of 1800mm from the finished floor surface.

The liquid membrane is to extend 75mm minimum each side of the corner.

Note: Use only insitu membrane materials appraised and approved by recognised authorities.

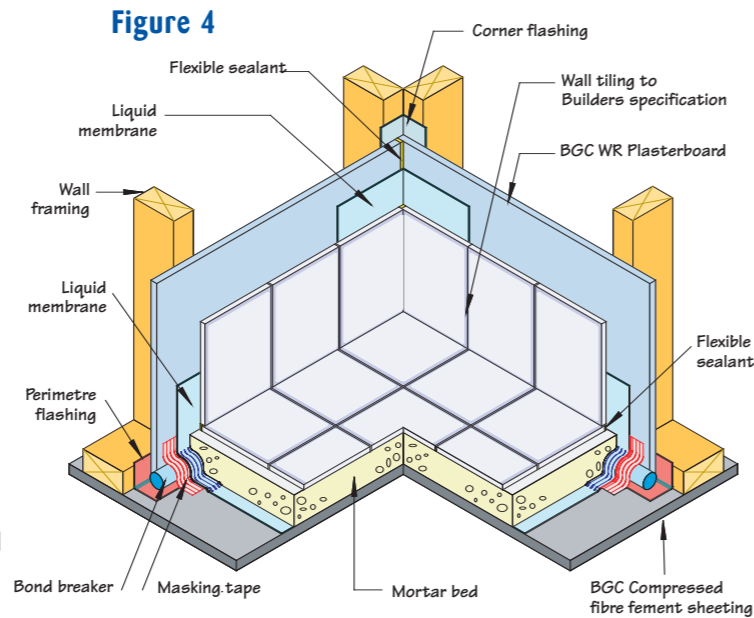
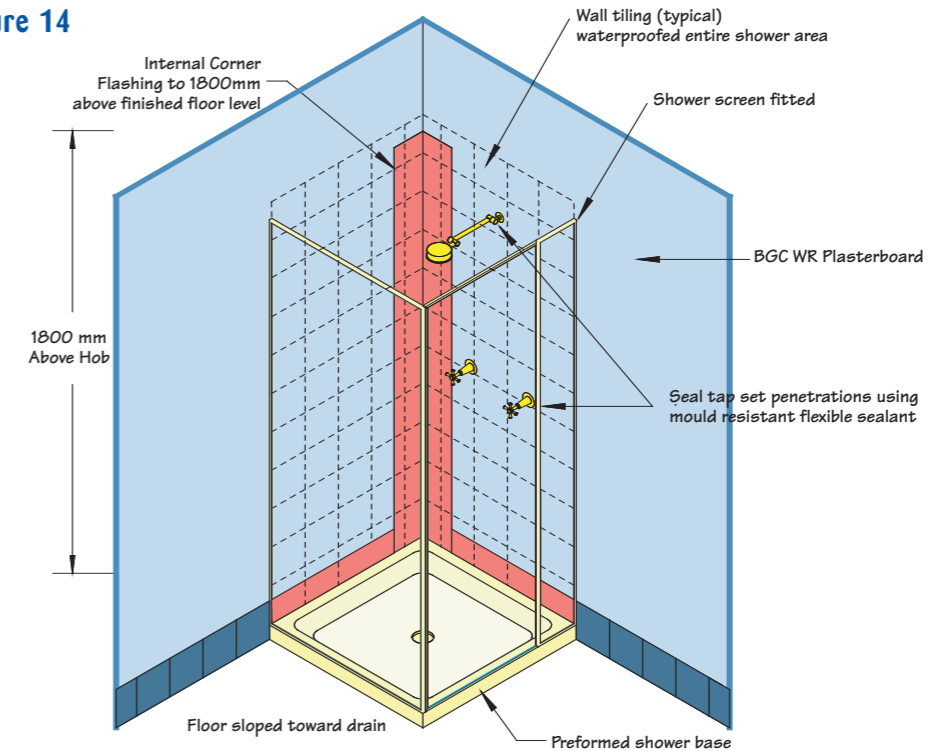

Figure 14



Shower Over Bath

Preliminary work and fixing out detail is similar for preformed shower bases and in part the insitu tray details, see Figure 13.

Cut and install PVC corner angle, down inside the bath up-stand flange and fasten to framing at 600mm centres, in a staggered pattern, see Figure 5.

Seal the lower edge of water resistant plasterboard sheets, whether cut or not, with a proprietary wet-area acrylic sealant, to prevent potential moisture wicking.

Install and fix sheets to the wall framing, as outlined previously 6mm clear off the bath up-stand.

Caulk the bottom edge of the sheets and the bath edge around plumbing fixtures with a mould resistant flexible sealant.

Apply a proprietary branded liquid membrane 150mm above the bath edge and wall surround, to a minimum height of 1800mm above the finished floor level and 75mm each side of the corner, see Figure 5 & 13.

Perimeter and Bath Flashing

Vertical corner is to angle finish inside perimeter wall angles and also pre-fabricated shower tray/base, insitu-laid trays or the like Refer Figure 5.

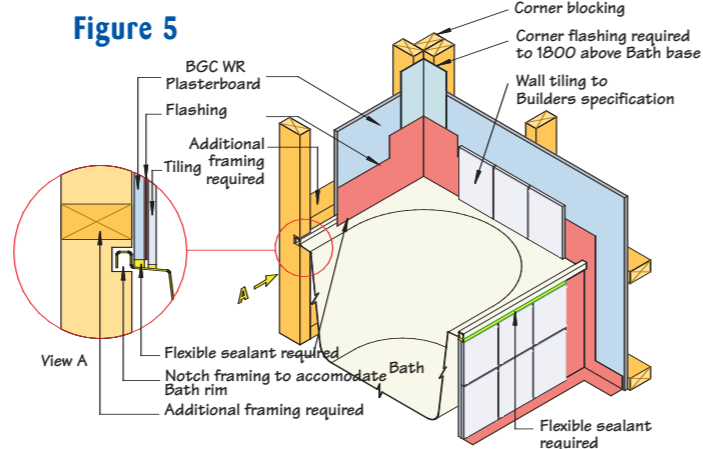

Table 7 - General Requirements for Extent of Application AS 3740-2004

Vessels or area where the fixture is installed	Requirements for elements				Figure No.
	Floors & horizontal surfaces	Walls	Wall junctions & joints	Penetrations	
Shower area Enclosed and hobbed	Waterproof entire enclosed shower area, including hob	Waterproof to 150mm min. above the shower floor substrate or 25mm min. above the maximum retained water level and the remainder to be water resistant to a height of 1800mm min. from finished floor level	Waterproof internal and external corners and horizontal joints within a minimum height of 1800mm above the floor level with a minimum width of 40mm either side of junction	Seal all penetrations	14
Enclosed and hobless	Waterproof entire enclosed shower area including water stop	Waterproof to 150mm min. above the shower floor substrate and the remainder to be water resistant to a height of 1800mm min. from finished floor level			
Enclosed and stepped down	Waterproof entire enclosed shower area including the stepdown	Waterproof to 150mm min. above the shower floor substrate or 25mm min. above the maximum retained water level and the remainder to be water resistant to a height of 1800mm min. from finished floor level			
Enclosed and preformed shower base	N/A	Water resistant to a height of 1800mm min. from finished floor level	Waterproof internal and external corners and horizontal joints to a minimum height of 1800mm above the floor level with a minimum width of 40mm either side of junction	Seal all penetrations	14

Australian Standards

The following tables are the specific requirements for Wet Areas taken from the Australian Standards 3740-2004 and are applicable to areas lined with BGC WR Plasterboard.

Wet Areas

“An area within a building supplied with water from a water supply system and includes bathrooms, showers, laundries and sanitary compartments. Excludes kitchens, bar areas, kitchenettes or domestic food and beverage preparation areas”.

The BCA requires that all wet-area design, construction and materials, do not create unhealthy, dangerous conditions, or damage to building components, caused by dampness, water overflow, infiltration or penetration.

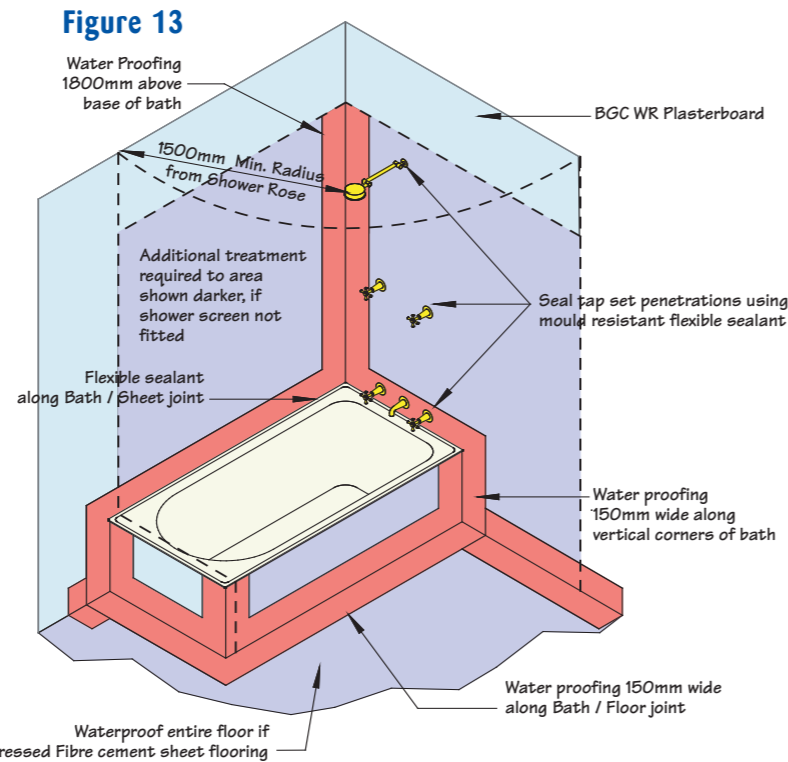

Structural Movements and Control Joints

Buildings and their component parts move over time due to various factors which may lead to building and or system failures if design, materials and installation are not satisfactory.

To minimise the risk of system failure take care when designing, detailing, installing and finishing all aspects of wet areas.

The design of wet areas must take into account any relative movements in the building structure and components, due to loading and temperature and humidity variations and the like. See Figure 6.

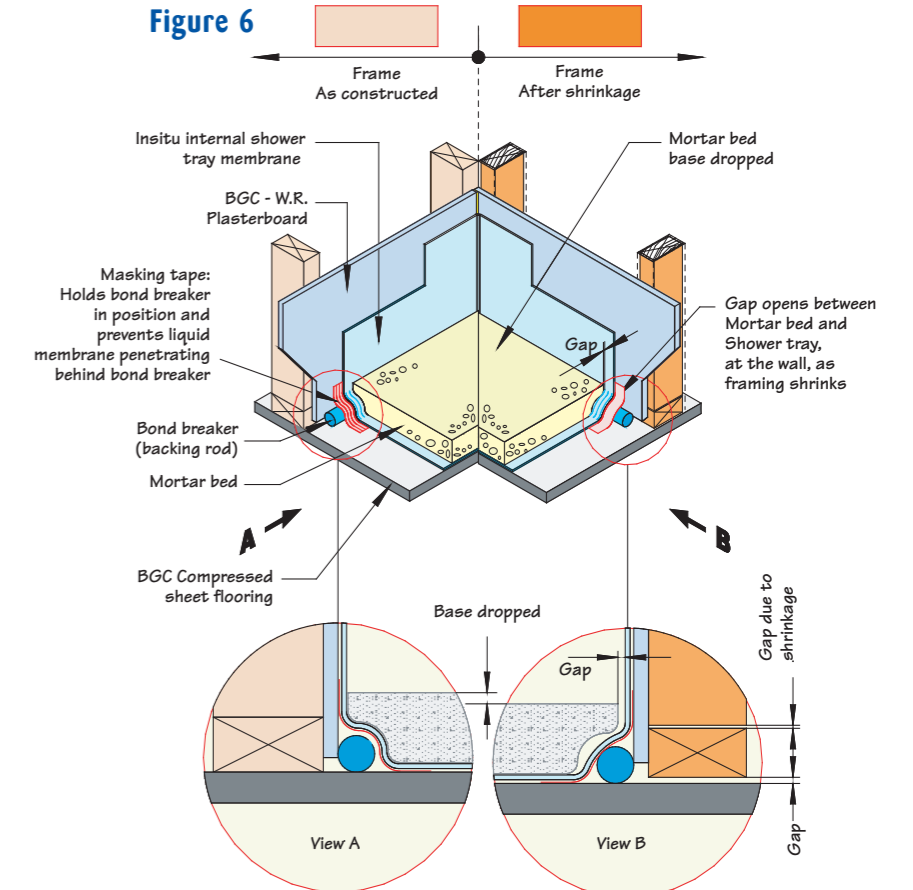

Table 6 - Design and Installation for Wet Area Waterproofing AS3740-2004

Vessels or area where the fixture is installed	Level of risk	Design and installation criteria				Figure No.
		Floor	Walls	Junctions	Penetrations	
Shower area	High	Waterproofed and drained	Water resistant	Waterproof	Waterproof*	14
Bathrooms	Medium	Concrete and compressed fibre cement sheet flooring Water resistant†	N/A	Waterproof‡	N/A	13, 15
		Timber floors including particleboard, plywood & other materials Waterproof	N/A	Waterproof‡	N/A	
Areas adjacent to baths and spas§ (applies to all rooms in which a bath or spa is installed)	Medium	Concrete and compressed fibre cement sheet flooring Water resistant†	Water resistant§	Waterproof	Horizontal surface Waterproof* Vertical surface Water resistant	13, 15
		Timber floors including particleboard, plywood & other materials Waterproof	Water resistant§	Waterproof	Horizontal surface Waterproof* Vertical surface Water resistant	
Walls adjoining other vessels (e.g., sink, basin or laundry tubs)	Low	N/A	Water resistant	Waterproof	Horizontal surface Waterproof* Vertical surface Water resistant	15
Laundries and WCs	Low	Water resistant†	N/A	Water resistant‡	N/A	
Bathrooms and laundries requiring a floor waste in accordance with Volume One of the BCA	High	Waterproofed and drained	N/A	Waterproof‡	Waterproof where through the floor, otherwise N/A	

LEGEND: N/A - Not Applicable *Including mechanical fixings or fasteners through surface materials ‡ Wall/floor junctions only †Where floor waste is provided the floor shall be graded to the waste §If a shower is included in a bath, include the requirements for shower area walls

Control Joints

In long runs of wall, control joints should be set at 5.4 metres maximum in non-tiled areas, and at 4.2 metres maximum, in tiled areas or at construction joints, which ever is the lesser. Control joints must allow for the differential expansion and contraction between the structure, wall lining and tiles. Control joints, must be constructed with double studs, with a gap to suit the control joint type. Refer Figure 7.

Figure 7

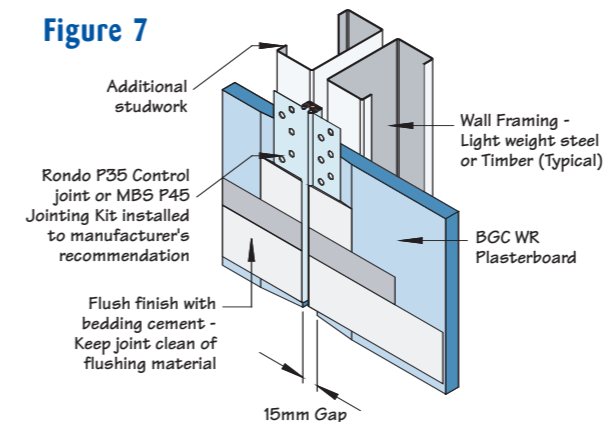

Corner Jointing

Corners are set and finished with paper tapes in wet areas for internal corners, or casing beads for external corners.

However, in wet area construction, corners above pre-formed shower bases, insitu trays and shower over-baths situations require special attention to detail, as noted.

Vertical Corner Flashing

In tiled walls, vertical corner flashings finish inside pre-fabricated shower tray/base, insitu-laid trays or the like. Refer Figure 8.

Figure 8

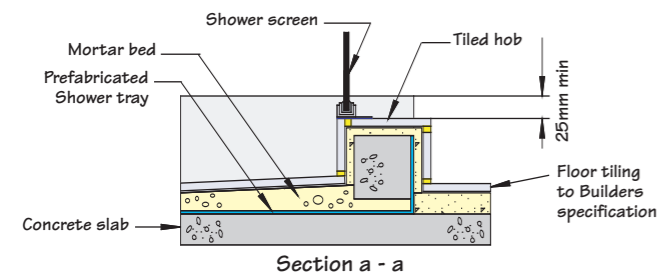
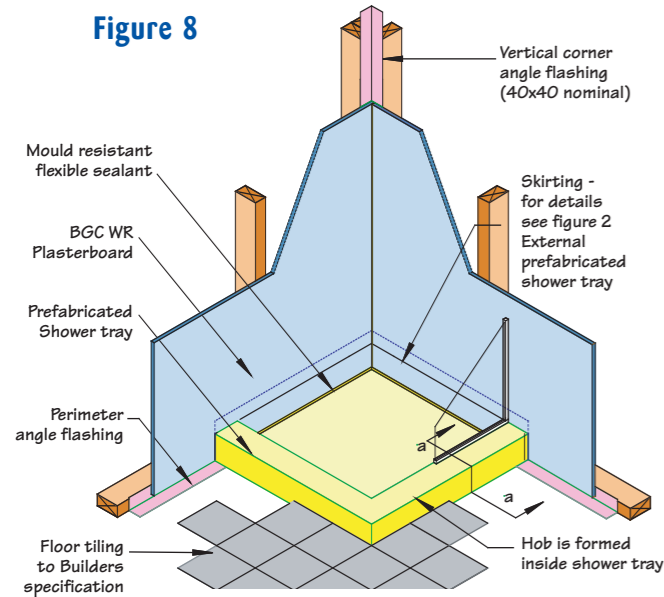

Jointing

Wet area plasterboard joints must satisfy the BCA requirements and comply with AS 2589.1:1997

All WR plasterboard joints in wet areas must be set with perforated paper tapes and proprietary branded base and flushing compounds.

The wet area base-coat system is typically a two-coat system under tiled areas and a three-coat system where tiles are not used.

All horizontal, vertical and corner joints and fastener points must, be stopped and set with the same compounds, to ensure water resistance across the wall areas.

The use of correct materials, application and sequencing of taping and jointing is important and any deviation may result in joint failure.

Mixing of different proprietary compounds or application of setting type compounds over acrylic drying compounds, may lead to joint failure and will negate any proprietary item warranties.

Only use drying type topping or finishing compounds over water-resistant acrylic drying type base-coat compounds.

NOTE: Do not use setting type compounds over water-resistant acrylic drying type compounds.

Do not use self adhesive tapes.

Table 3 - Tiled Areas

First Coat	Tape	Second Coat	Finish Coat
Wet Area Base Coat	Paper Tape	Wet Area Base Coat	None Required

Table 4 - Tiled Areas: - Non-Wet Areas

First Coat	Tape	Second Coat	Finish Coat
Wet Area Base Coat	Perforated Paper Tape	Wet-Area Base Coat	None Required

Table 5 - Non-Tiled Areas: - Non-Wet Areas

First Coat	Tape	Second Coat	Finish Coat
Base Coat	Paper Tape	Base Coat	Topping Coat

First Coat and Tape

- Wipe joint recesses with damp cloth to remove dust from plasterboard face.
- Fully fill recess evenly with wet area base coat.
- Centrally bed the paper tape into bed coat and cover lightly with wet area base-coat compound and allow to fully dry.
- Cover all fastener points with wet area base-coat compound and allow to fully dry.

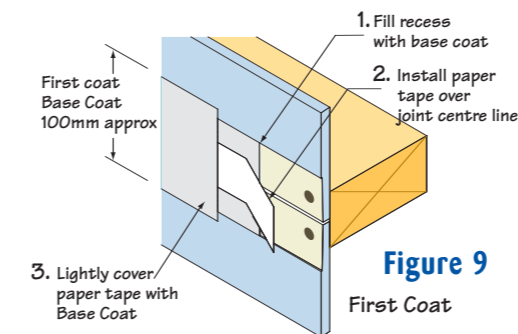

Second Coat

- Apply the second coat of wet area base-coat compound, 180mm wide and feather out the edges and allow to fully dry.
- Apply a second coat to all fastener points, feather out 25mm and allow to fully dry.
- When the coating compounds are dry, lightly sand all joints and fastener points.

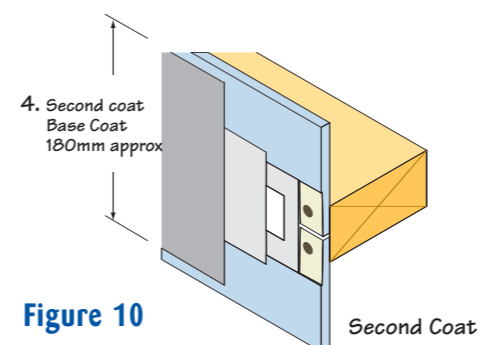

Finish Coat

The finish coat is only required where tiles are not used and another decorative finish is required.

- Apply a 280mm wide approximate, thin finish coat, centrally over the second coat.
- Dampen the outer edges with a sponge to feather out the edges of the finish coat and allow to dry.
- Apply a thin finish coat over all fastener points and feather out 40mm and allow to dry.

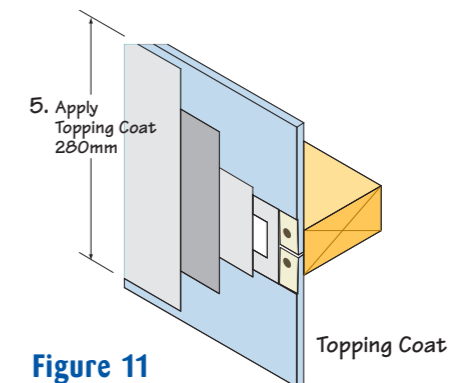

Figure 11

Sanding and Finishing

- Allow joint and fastener point coating compounds to dry for 24 hrs before sanding.
- For tiled areas lightly sand all joints and fastener points, with 150 grit or with 220 sanding mesh, to remove any high spots.
- Wipe off excess dust with a slightly damp cloth, prior to the application of tile adhesive, seal coats or decorative finishes.

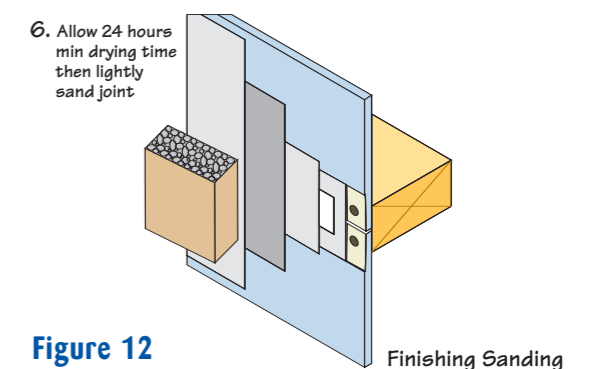

Figure 12